



Thank you for purchasing A-1's Herty Gerty Key Cutter.
With proper care and use, you are assured of trouble-free and accurate operation.

BASIC OPERATION

Take the key to be copied & decode it. Write down the code & its position around the body of the barrel. The depth of the cut is set by turning the micrometer adjusting nut, Fig. 4. The pointed end of the crank handle will point to the desired depth of cut. The lock screw (Fig. 4) determines the correct position, not the centering of the number. Make sure that the lock screw centers in the detent hole. Don't over tighten this screw. Time can be saved by cutting similar depth cuts. For instance, if you have three 5 depth cuts, set the micrometer adjusting nut for a five depth, and cut all three positions.

Fig. 1 demonstrates the correct way to hold and operate the machine. Turn only in a clockwise direction. (A bench mounted holding fixture is available for ease of operation).

Fig. 2 demonstrates the palm cushion which slips over the bow to cushion the palm of your hand.

Fig. 3 identifies positions of the dial so that it can be rotated right or left of center to accommodate keys that are cut off the center line.

Each machine is supplied with a standard cutter, two set screw wrenches, a standard dial, a decoder and a palm cushion. Accessory dials are available and may be interchanged by removing the Phillips screw. Make sure that there is no foreign matter under the dial.

Set the desired position of the dial with the center line on the machine body, such as center, left or right. Do not force any blank on the dial's hub! If the blank doesn't fit, do not use it! This is a precision instrument & should be handled with care.

Cutters are designed to operate by hand power only! Warranty is void if operated by pistol drill or motor. The large diameter cutter is used to cut the standard and 'S' style key and the major diameter of the 137A key.

When installing accessory dials or cutters, you must calibrate the machine for accurate depth of cut. Take an original cut key, and decode 1 of the depths. Place this key on the index hub with the known depth in the cutting position (Fig. 4) Remove the spindle and loosen the cutter lock screw approximately 1/4 turn (Fig 5). Set the micrometer adjusting nut to the depth of the key you just decoded. Place spindle back into machine. Next, enter the 1/8 set screw wrench through the handle into the cutter adjusting screw (Fig. 4). By turning this screw clockwise, it will move the cutter outward. To move the cutter back, reverse the operation by pushing the cutter back with you set-up key or fingers. Adjust the cutter until it just touches the set-up key. When adjusted, lock the cutter with the set screw (Fig. 5). Do not over tighten! You are now calibrated to the correct cut depths. This calibration will remain constant until you have to change the dial or cutter.

Keep your machine clean and stored in the case when not in use. Lubricate the spindle and back face of the machine with Vaseline. When the machine leaves our factory, it is set to cut standard center 137 blanks. PLEASE NOTE THAT THIS MACHINE IS DESIGNED TO CUT CHICAGO "ACE", FORT LOCK "GEM", TAYLOR AND ALL OTHER 137 TUBULAR KEYS WITH .016 DEPTH OF CUT.

Accessories: #CS Small Cutter - Used only for the minor diameter of the 137A key (requires the accessory dial #HGD137-A). #HGD137-A: Large diameter dial (Requires #CS cutter). #HGD137-S : Small diameter dial. #HGBM Bench Mount.

Replacement Parts: #CL Standard Cutter. #HGD137 Standard Dial

FOR TECHNICAL SERVICE AND QUESTIONS ABOUT OTHER A-1 PRODUCTS VISIT OUR WEBSITE AT

WWW.DEMANDA1.COM

**A-1 Security Manufacturing Corp.
3001 W. Moore St., Richmond, VA 23230
804.359.9003**

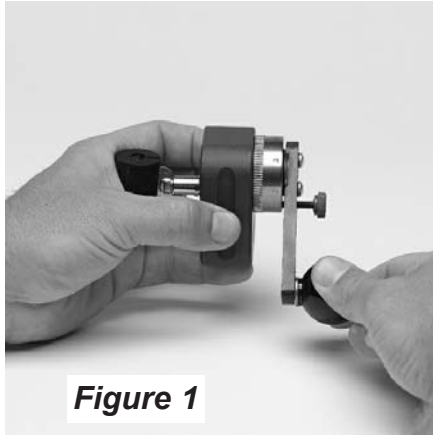

Figure 1

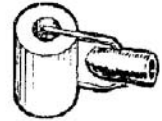

Figure 2



Figure 3 - 137 Blank Only

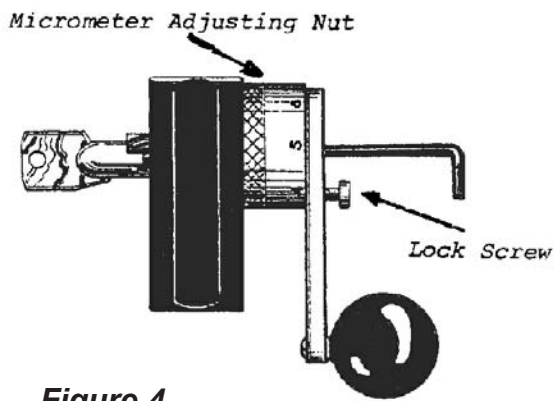

Figure 4

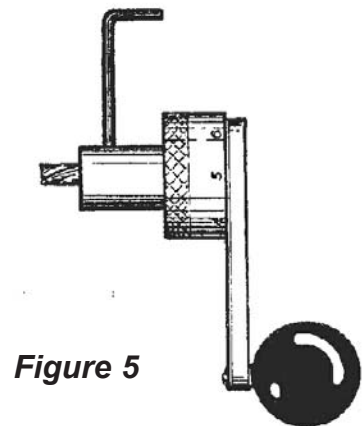

Figure 5